



TOP LED 7020



taping: 12 mm tape with 4000/reel,

viewing angle: Lambertian Emitter (120°)

Welding: IR Reflow Soldering Profile for lead free soldering, 260°C±5°C for 3 -5seconds. Wave soldering lead-free soldering 260°C±5°C for 3 -5seconds. Manual lead-free soldering 360°C±5°C for 2-3 seconds.

Package Outlines

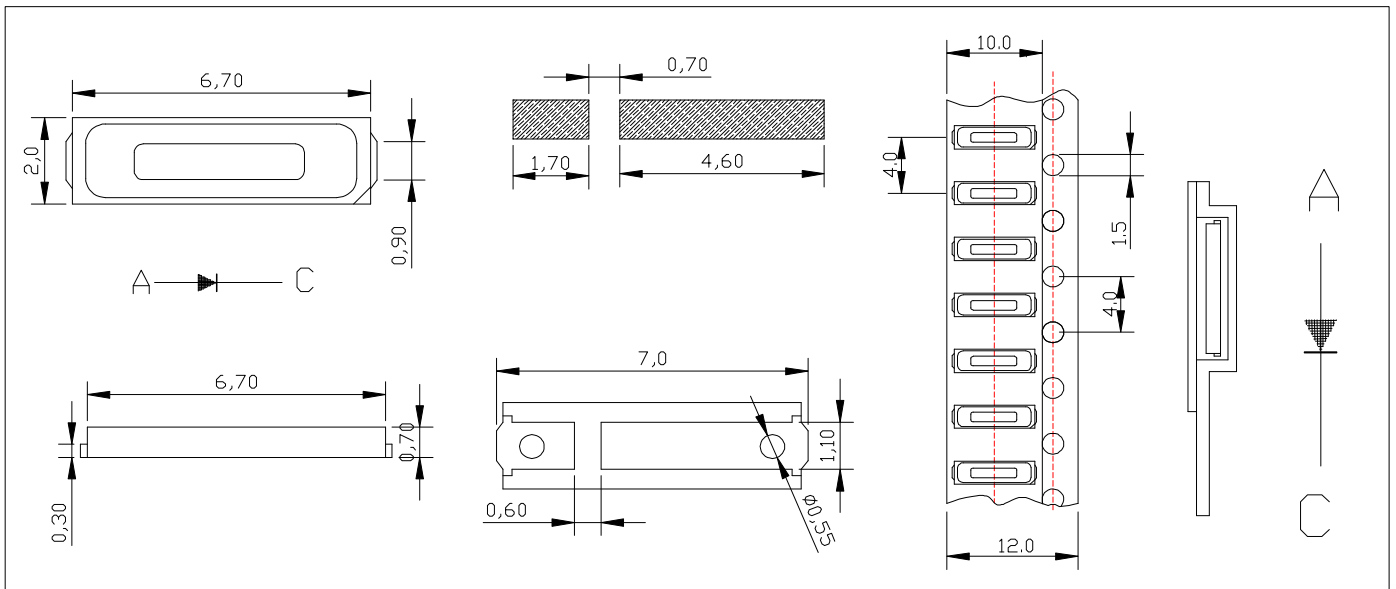

Note: 1. All dimensions are in millimeters (inches).
2. Tolerance is ±0.1mm unless otherwise noted.

Ordering Information

Type	Color of Emission	Adaptation current	Brightness Group	Wavelength
7020W TOP	White	$I_F = 150mA$	X0.30/Y0.30	40-80LM
-	-	-	-	-
-	-	-	-	-
-	-	-	-	-
-	-	-	-	-

Note: Please contact the salesman for detailed specifications!